

## AUTOMATIC LEVEL SWITCHES

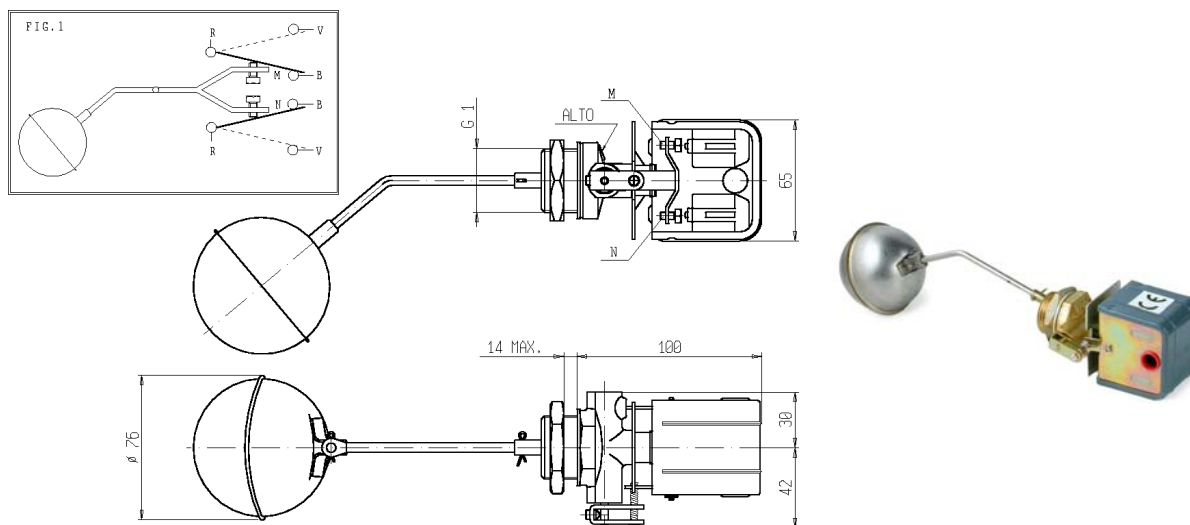

**FEATURES** - Device designed to control the water level into pressurized or non-pressurized tanks. Fitted by two electric deviation switches, fast and non-vibration type with silver-plated contacts: one operating on the minimum level and the other one on the maximum level.

**DEFINITION AS PER EN 60730-1§2.7.2.**

The A225 is a control device in class 0 in which the protection against the electric discharges is given by the main insulation; it means that the accessible parts are not connected with any protection wiring that is part of the device. In case of failure of the main insulation the environment gives the protection.

**CONSTRUCTION** - Body in brass, sealing gasket in PTFE (Polytetrafluorethylene), float ball in stainless steel. Internal parts in brass and stainless steel. Electric parts contained in a zinc plated steel housing with two wire bushing in synthetic rubber suitable for cables Ø 12 mm. Cover in varnished steel.

**MAIN INSULATION AS PER EN 60730-1-§ 2.7.10**

The main insulation is the insulation of the alive parts needed to guarantee the main protection against electric discharges; in this device it is given by the junction box of the micro-switch made in PSU (Polyphenylene sulfide).

**PROTECTION DEGREE** - IP30

**AMBIENT TEMPERATURE** - 80°C maximum

**CALIBRATION** - Adjust either screw "M" for the minimum level or screw "N" for the maximum level so to set the operating points (see fig. 1).

| MALE COUPLING SCREW | MAX PRESSURE (bar) | MAX MEDIUM TEMP. (°C) | ADJUSTABLE DIFFERENTIAL LEVEL (mm) | SERIE S AND TYPE | MAX BREAKING CAPACITY (contacts)  | NOTES | WEIGHT (kg) |
|---------------------|--------------------|-----------------------|------------------------------------|------------------|---|-------|-------------|
| G 1                 | 10                 | 160                   | 15 ÷ 85                            | A225-10          | Contacts RB<br>220 V c.a. 15A<br>380 V c.a. 10A<br><br>Contacts RV<br>220 V A.C. 10A<br>380 V A.C. 6A | 1-2   | 0,720       |

- NOTES**
- For connection to junction-box the use of eyelet or fork thimble is suggested
  - 1 - Both rod and float-ball are fitted by several holes so to enable different mounting position (see overleaf). In applications for boilers, hard waters and any encrusting media set the unit so that the rod is at least 15 mm above the maximum level.
  - 2 - Rod of floating ball fitted into AISI 304 stainless steel tube.

0109/1506

## EXAMPLES OF ROD - FLOAT BALL ASSEMBLY

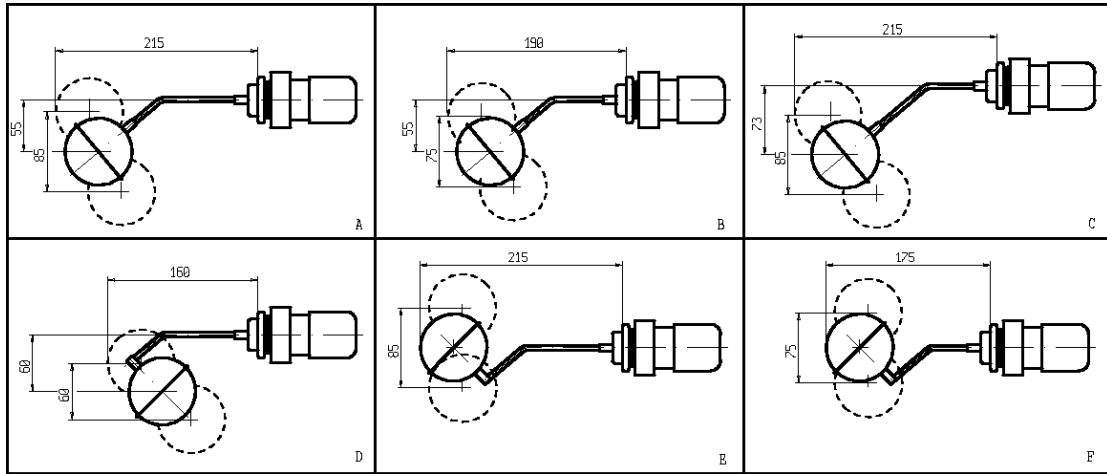

## SPARE PARTS A225

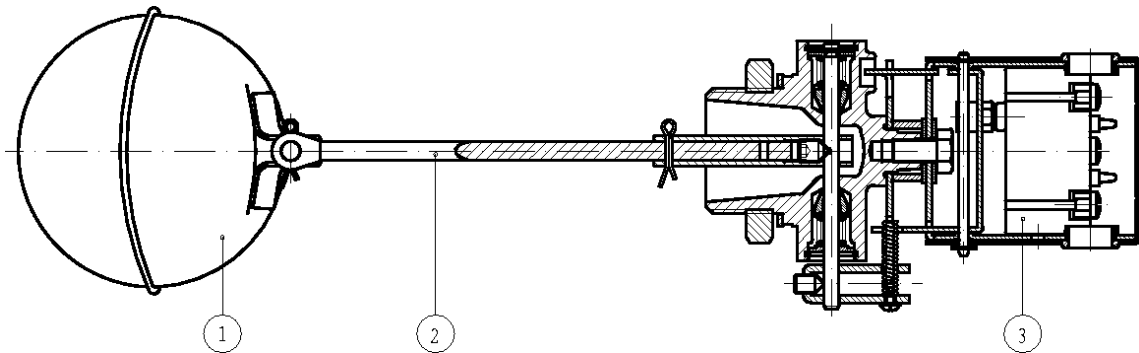

### Kit description

Float ball  
Connecting rod  
Micro-switch group

### Kit P.N.

1742901R  
1936201R  
2025001R

### Consisting of:

Float ball pos. 1  
Connecting rod pos. 2  
Micro-switch group pos. 3

THE VALIDITY OF REPORTED DATA IS REFERRED TO THE DATE OF ISSUE. POSSIBLE UPDATES ARE AVAILABLE ON REQUEST